

# Product Datasheet

## EXP-SD-18G EXP-SD-18GS

### Outdoor Self-Draining Emergency Safety Shower

Self-draining emergency safety shower suitable for hot climates. The design allows standing water to drain away from the standpipe to ensure the delivery of tepid water. The valve is situated directly above the water inlet; the bleed pipe is fitted above this so standing water can drain into the ground preventing stagnant water overheating from solar radiation and removing the risk of further injury to the operator. Available with galvanised mild steel or 316L stainless steel pipework.

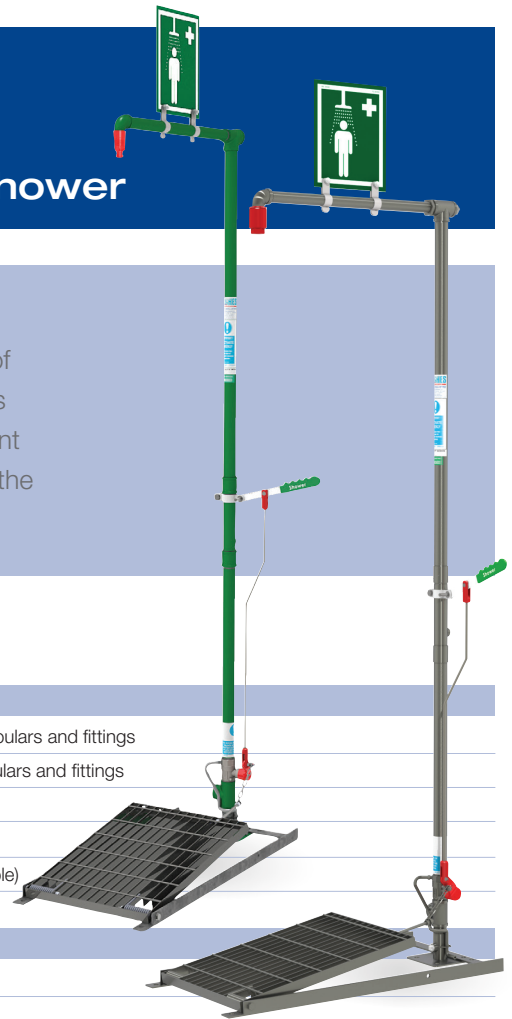

## Specifications

### MATERIALS OF CONSTRUCTION

PIPEWORK AND FITTINGS (G)	Galvanised mild steel with 150lb medium wall tubulars and fittings
PIPEWORK AND FITTINGS (GS)	316L stainless steel with 150lb medium wall tubulars and fittings
OPERATING VALVES	316L stainless steel, two piece stay open valve
SHOWER SPRAY OUTLET	Machine moulded nylon 6 red shower nozzle
STANDARD FINISH (Galvanised mild steel)	Green powder coated (alternative colours available)
STANDARD FINISH (Stainless steel)	Polished brush finish (paint options available)

### SERVICES

WATER INLET	1 <sup>1</sup> / <sub>4</sub> " Female BSP
DESIGN OPERATING PRESSURE	1.5 to 6 BAR G (22 to 87 PSI) (higher supply pressures accommodated with the incorporation of the optional pressure reducing valve)
TEST PRESSURE	10.3 BAR G (149 PSI)
MINIMUM FLOW AT OPERATING PRESSURE	Shower: 76 litres/minute minimum (20 US Gallons)

### ENVIRONMENTAL OPERATING TEMPERATURE

MINIMUM AMBIENT OPERATING TEMPERATURE	5° C (41° F) - (0° C (32° F) if valve is insulated)
MAXIMUM AMBIENT OPERATING TEMPERATURE	45° C (113° F)

### OPERATIONAL

SHOWER SPRAY OPERATION	Hand lever (optional foot panel for hands free operation)
------------------------	---

### WEIGHTS and DIMENSIONS

DIMENSIONS - STANDARD ORIENTATION (WxDxH)	370mm (14.6in) x 750mm (29.5in) x 2300mm (90.6in)
WEIGHT (NO OPTIONS)	15kg (33lb)

View our Guide to the ANSI/ISEA Z358.1-2014 International Standard for Emergency Eyewash and Shower Equipment at [www.hughes-safety.com](http://www.hughes-safety.com)



# HUGHES



HUGHES-SAFETY.COM

[www.hughes-safety.com](http://www.hughes-safety.com)

**EXP-SD-18G**  
**EXP-SD-18GS**

*Outdoor Self-Draining Emergency Safety Shower*

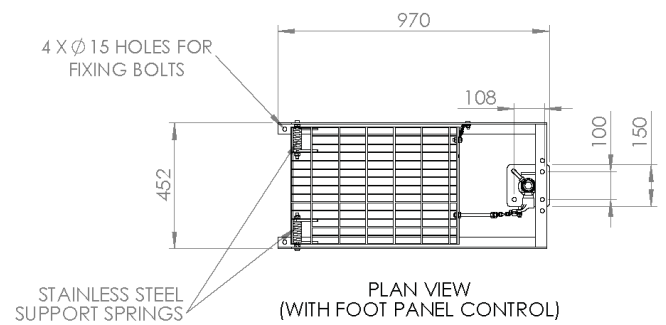
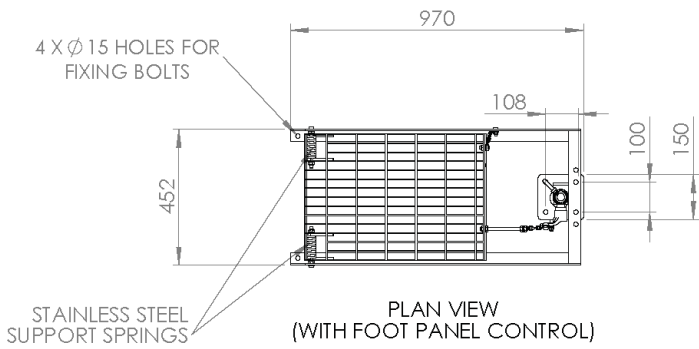
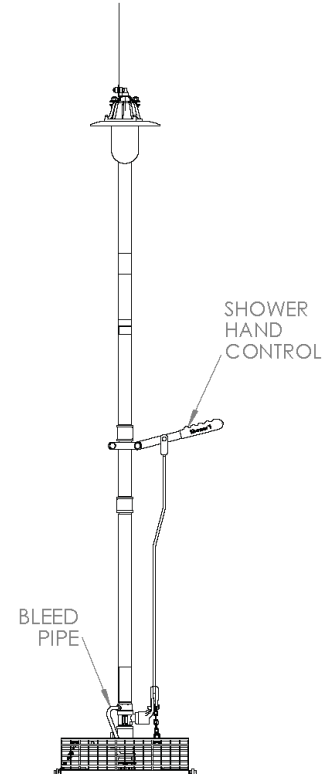
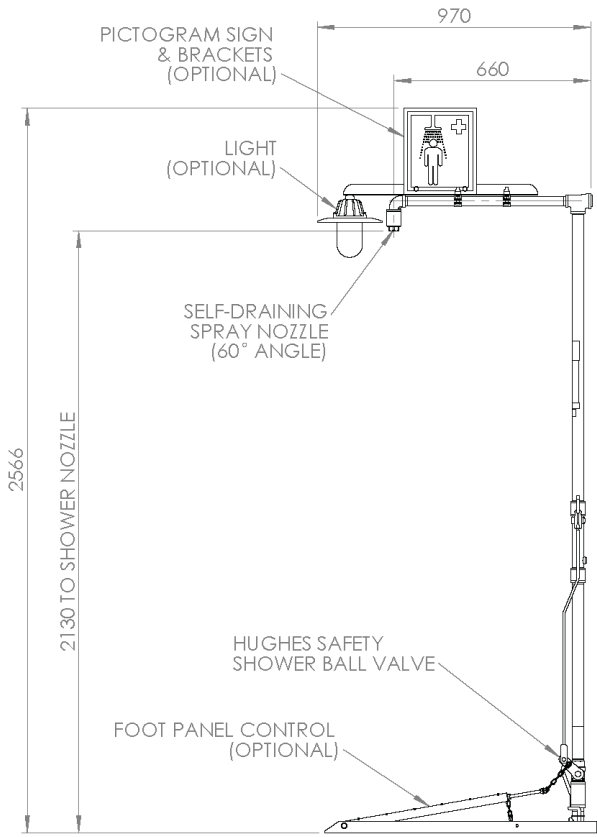

**HUGHES**



**HUGHES-SAFETY.COM**

a Justrite® Group Company

Hughes Safety Showers Ltd, Whitefield Road, Bredbury, Stockport SK6 2SS UK.

Email: [info@hughes-safety.com](mailto:info@hughes-safety.com)

Tel: +44 (0)161 430 6618

Registered No. 0939240. VAT Registration No. 918 5005 32. Hughes Safety Showers Ltd is a Justrite Group Company.